



C.C. Steven & Associates Inc. – Since 1978

CCSTAND Assembly Instructions (Portable and Fixed mount versions)

Assembly Instructions For Stands

1

Layout the bars and identify the by length. Bars in your kit are as follows:

Portable Stand Kit (6 Bars)

- 2 identical 54.5" Bars (with no machining)
- 2 identical 30" Bars (with machining on 2 sides of each end)
- 2 identical 20" Bars (with machining on 1 end only)

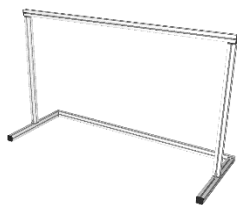

Mounted Stand Kit (3 Bars)

- 1 54.5" Bar (with no machining)
- 2 identical 30" Bars (with machining on 2 sides of each end)

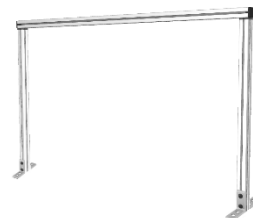

2

Identify the other hardware that is in your kit by name.

Portable Stand Kit

- 6 Anchor Fasteners – to connect bars together
- 2 L Brackets – to connect FAN to overhead bar
- 4 T-Nuts – to connect L bracket to upper bar
- 4 Flanged Button Screws – to connect L bracket to upper bar
- 6 End Caps – to cover exposed ends of the bars when finished



Mounted Stand Kit

- 2 Anchor Fasteners – to connect bars together
- 4 L Brackets – 2 to connect FAN to overhead bar, and 4 to mount stand to table top
- 4 T-Nuts – 4 to connect L bracket to upper bar, and 8 to mount 4 L brackets to bottoms of vertical bars
- 4 Flanged Button Screws – 4 to connect L bracket to upper bar, and 8 to mount 4 L brackets to bottoms of vertical bars
- 6 End Caps – to cover exposed ends of the bars when finished



3

Connect 2 L Brackets To A 54.5" Bar Using the T-Nuts and Button Head Screws

You will only be adding t-nuts and screws to one side of the L bracket (both sides of the bracket are the same so it doesn't matter what side. After you pre-load the t-nut and screw to one side of the L bracket, slide the 2 t-nuts into the slot of the 54.5" bar. Continue to slide them to the center of the bar and loosely tighten them for now.

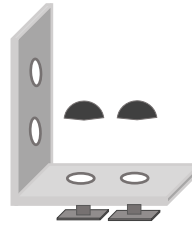

Do the same thing for the 2nd L bracket. Notice how the fasteners are on the inside of the brackets when properly mounted.

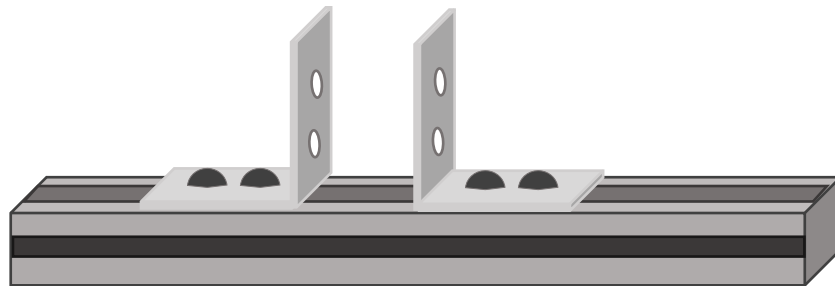

4

Insert The Anchor Fasteners Into the 30" Bars – there is one bore (hole) on each end, but they are not on the same side.

Now slide one of the anchor fastener t-nuts into the same bar you just added the L brackets to. Slide it in the exact same slot – but make sure the anchor fastener is on the inside corner, not the outside. When ends are flush, tighten the anchor fastener.

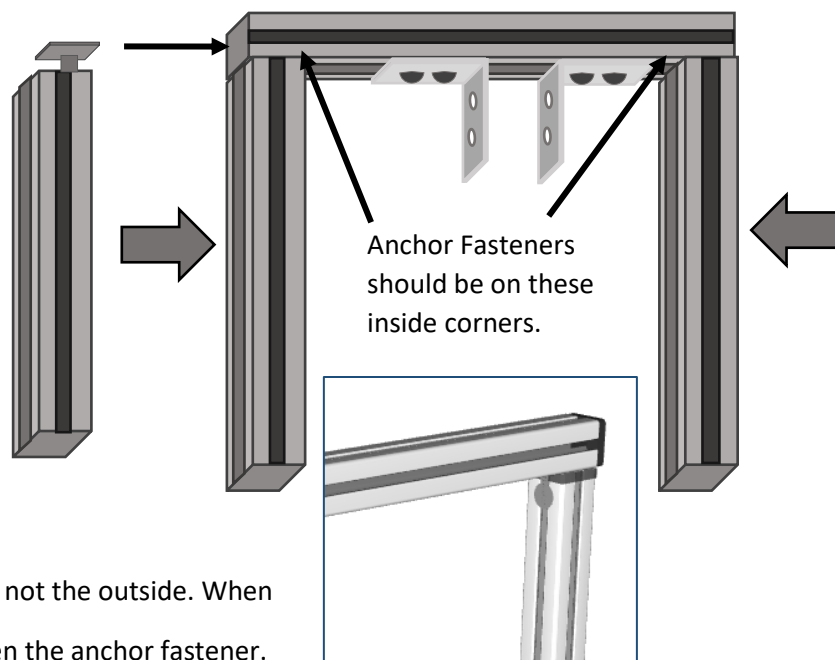

Your U shaped structure should be rigid now.

If you are installing the permanent stand, skip down to Step 7. If you are installing the portable stand, continue with Step 5.

5

We Are Now Going To Connect The Bottom Legs To The U-Shaped Structure.

Two things to note here. If your lower anchor bore holes on the vertical 30" bars are not on the same sides, then you may need to slide one off and reverse it so it matches. When done properly, the upper anchor fasteners will be on the inside of the upper corners, and the anchor bores on the bottom of the vertical bars will be both facing the same direction.

Make sure that the anchor fasteners are pre-loaded into the holes at the bottom of the 30" vertical bars you just connected to the 54.5" bar.

Now rotate one of the 20" bottom bars until anchor bore is facing inward (see drawing below).

Now slide the first bottom 20" bar onto the vertical bar so it look similar to this.

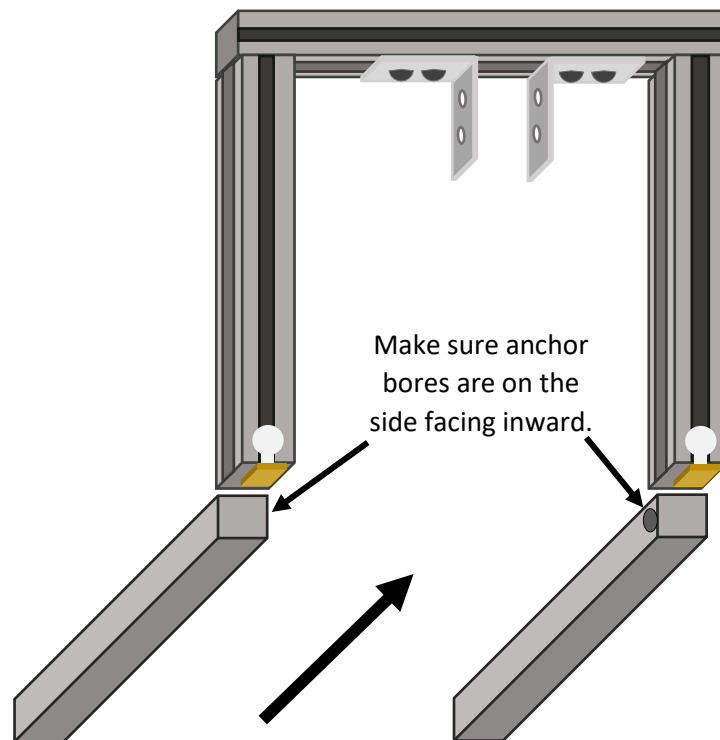

Center the lower bar so the vertical is in the center of the lower bar and tighten the anchor fastener.

Repeat on other side.

Load the remaining two anchor fasteners in the bottom 20" bars – the bore holes should both be facing inward as illustrated on the previous drawing. When you have the anchor fasteners installed, the t-nuts will both be sticking out in the same direction.

6

Take the unused, remaining 54.5" bar and slide it onto the first anchor fastener t-nut with the slot that faces the structure. While sliding the first t-nut, slide the bar until the 2nd t-nut of the 2nd fastener is also in the same slot. The bar should now be flush with both 20" bars. Tighten the two anchor fasteners.

If you did not center the vertical bars or the lower horizontal bars, you can loosen and retighten the anchor fasteners to make sure everything looks right.

Should look like this.

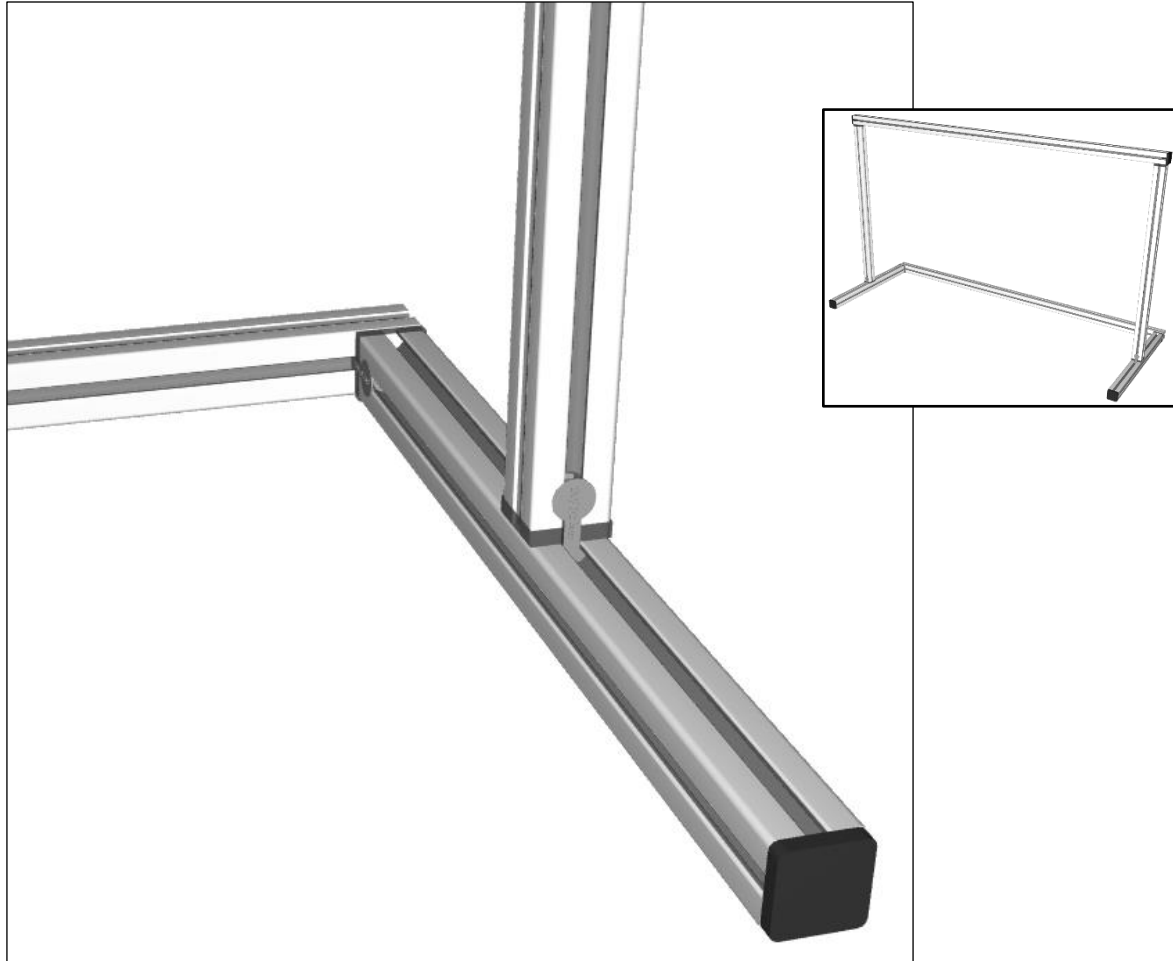

Skip ahead to Step 9

*****For permanent Stand Assembly...**

- 7** Pre-load the remaining screws and t-nuts onto one side of each of the remaining L brackets.
- 8** Connect The L Brackets to the Bottom of the Vertical Bars – one on each side facing forward and backward. When the bracket is flush with the bottom of the bar, tighten all screws.

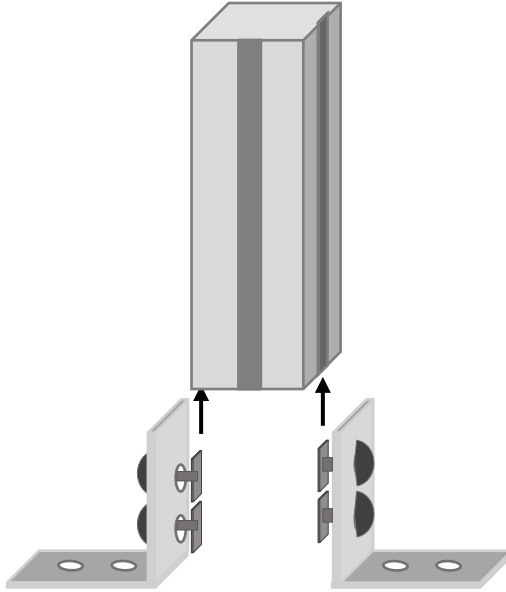

Your frame should now be ready to mount to the table top surface (hardware not included).

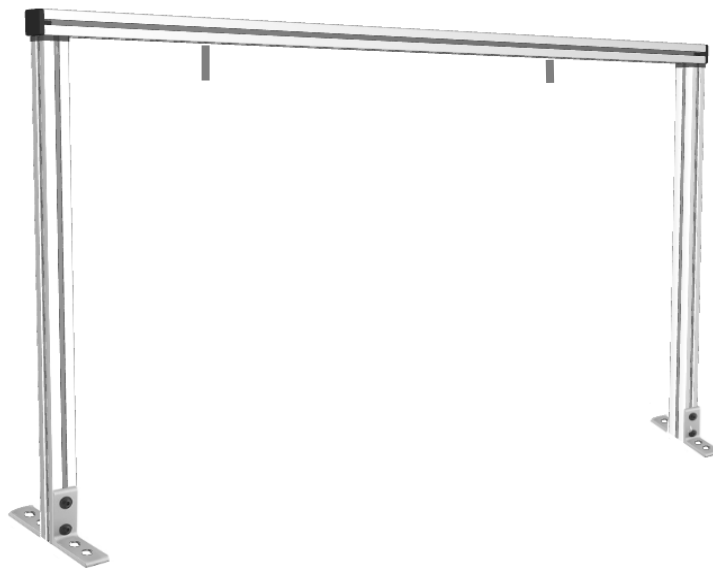

- 9** Both types of stands come with push-pin end-caps for the ends of bars. Add these to finish your frame.